

W803E Battery Powered
Electromagnetic Converter

User Manual

April, 2023

CONTENT

1 Brief	1
1.1 Product characteristics	1
2 Converter Picture	1
3 Display and Operation	2
3.1 Meter Mode	4
3.2 Meter Wake-up	5
3.3 Sleep Mode Setting	5
3.4 Change between Measurement Mode and Test Mode	6
3.4.1 Measurement Mode into Test Mode	6
3.4.2 Test Mode into Measurement Mode	6
3.5 Parameter Setting	6
3.5.1 Parameters Setting and Remote Control Operation	6
3.5.2 Function Selection Display	7
3.6 Clr Total Record	8
4 Converter Wiring	8
4.1 Definition of Signal Line	8
4.2 Converter Waterproof Interface Definition and Wiring	9
4.2.1 Converter Waterproof Interface Definition	9
4.2.2 Converter Pressure Measurement Interface and Pressure Sensor Wiring ...	10
4.2.3 Converter Temperature Measurement Interface and Temperature Sensor Wiring	11
4.3 Converter Assembled Grounding Requirements	11
4.4 Flow Test	12
4.4.1 Pulse Output Wiring	12
4.4.2 Pulse Output and Calibration System Connection	12
4.4.3 Pulse Output Parameter Setting	12
5 Meter Parameter	13
5.1 Operate Mode	13
5.1.1 Operate Mode S	13
5.1.2 Interval Time	13
5.1.3 Meter Dormancy	13
5.1.4 Measure Mode	13
5.1.5 LCD Time Sleep	13
5.1.6 Backups Enable	14
5.1.7 SD_Card Enable	14
5.1.8 Humidity Enable	14
5.1.9 Bi_Direct Enable	14
5.2 Flow Parameters	14

5.2.1 Sensor Size	14
5.2.2 Flow Unit	14
5.2.3 Flow Range	14
5.2.4 Flow Direction	14
5.2.5 Flow Zero CRC	14
5.2.6 Flow Cutoff	15
5.2.7 Flow Filer Time	15
5.2.8 Reverse Flow En	15
5.2.9 Starting Value	15
5.2.10 Heat Display	15
5.2.11 High/Low Alm. Limit	15
5.2.12 Fluid density	16
5.3 Output Parameters	16
5.3.1 Pulse Out Enable	16
5.3.2 Pulse Unit	16
5.3.3 Pulse Factor	16
5.3.4 Pulse width	16
5.4 Sensor Parameters	16
5.4.1 FWD.Sensor Fact/ REV Sensor Fact	16
5.4.2 Excitation Time	17
5.4.3 Sensor Coding	17
5.4.4 Empty Pipe Value	17
5.4.5 Empty Zero CRC	17
5.4.6 Empty Range CRC	17
5.4.7 System Alarm Ena	18
5.4.8 Excit. Value Set	18
5.5 FWD or REV Linearization	18
5.5.1 Linearizati. Ena	18
5.5.2 FWD or REV Correct Po. or Target Val.1-4, FWD or REV End Velocity	18
5.6 Temperature Parameters	18
5.6.1 Heat Unit	18
5.6.2 Sensor Position	18
5.6.3 Temperature Filter	18
5.6.4 Ent.T、 Out.T Zero CRC,Ent.T、 Out.T Range CRC	18
5.6.5 Pressure Range	19
5.6.6 Ent.Temperature calibrate、 Out.Temperature calibrate	19
5.7 Communication	19
5.7.1 Comm Address	19
5.7.2 Communication Rate	19
5.7.3 Communicat. check	19

5.7.4 Communicat.Gap	19
5.7.5 IrDA Data Type	19
5.8 Factory Adjust	19
5.8.1 Language	19
5.8.2 Meter Factor	20
5.8.3 Meter Correct	20
5.8.4 Meter Code 1-4	20
5.8.5 Multiplier	20
5.9 Total Parameter	20
5.9.1 Flow Total Unit	20
5.9.2 Heat Total Unit	20
5.9.3 Clear Total Key	20
5.9.4 Forward and Reverse Total High and Low	20
5.9.5 Heat Total High and Low	21
5.9.6 Total Display	21
5.10 Pressure Parameters	21
5.10.1 Pressure Unit	21
5.10.2 P_Sensor Exit	21
5.10.3 Pressure Gain	21
5.10.4 Pressure Zero CRC and Pressure Gain CRC	21
5.10.5 Press. Hi/Lo. Alarm	22
6 Performance Indicators	22
6.1 Sensor Matching Requirements	23
6.1.1 Adjust excitation current by hardware	23
6.1.2 Adjust excitation current by software	23
6.2 Installation dimension diagram	24
7 Alarming Information	24
8 Error Disposition	25
8.1 No Display	25
8.2 Excitation Mode Alarming	25
8.3 Empty Pipe Alarming	25
8.4 Flow Measurement Inaccurate	25
8.5 Remote control Key Failure	26
Annex 1 Parameter Setting Overview	27
Annex 2 Function of Nonlinear Correction	31
Annex 3 Information Record Function	32
Annex 4 Installing and connecting of pressure sensor	33
Annex 5 The selection of P_Sensor Excit and Pressure Gain	34
Annex 6 Heat Measurement Instructions	35
Annex 7 Waterproof connector wiring method	37

F7.1 wiring and gluing method of W803E converter waterproof box	38
Annex 8 Communication wiring method	41
Annex 9 Instructions for HART communication module	42
Annex 10 Precautions for use of converter	45

1 Brief

W803E is the latest battery powered electromagnetic converter in L-mag series.

1.1 Product characteristics

1. W803E has high stability and measurement accuracy (up to 0.5 level);
2. Low power consumption: a standard battery can work for 3-6 years (determined by the excitation current);
3. Dual power supply: W803E is equipped with external power supply interface, which can be powered by external 12-24vdc power supply, enabling users to have a variety of power options;
4. Multiple network interfaces: W803 has GPRS, RS485, HART and other network communication for users;
5. Multiple work mode: W803E has 'Flow Only' mode, 'Flow + Pressure' mode, 'Flow + Temperature' mode for users.

2 Converter Picture



Fig2.1 Integrated W803E



Fig2.2 W803E with GPRS communication

3 Display and Operation

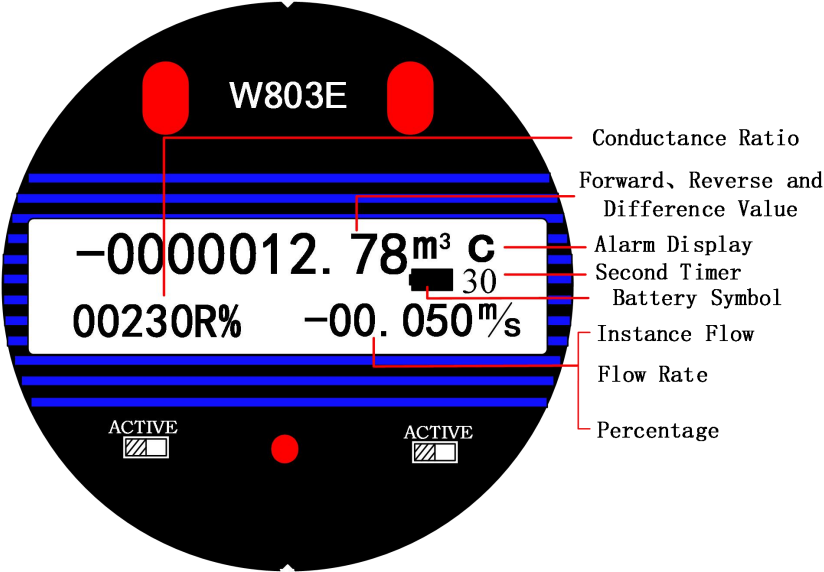

Fig3.1a W803E Converter LCD (Only Flow Mode)

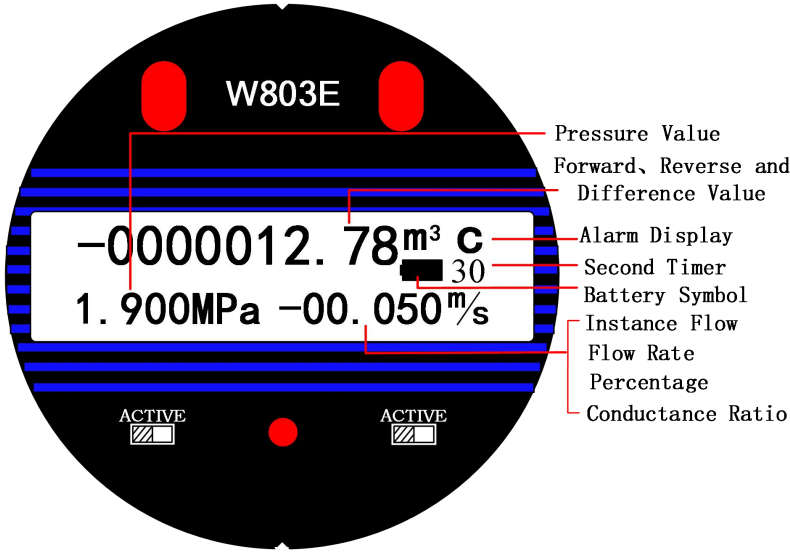

Fig 3.1b W803E Converter LCD (Flow + Pressure Mode)

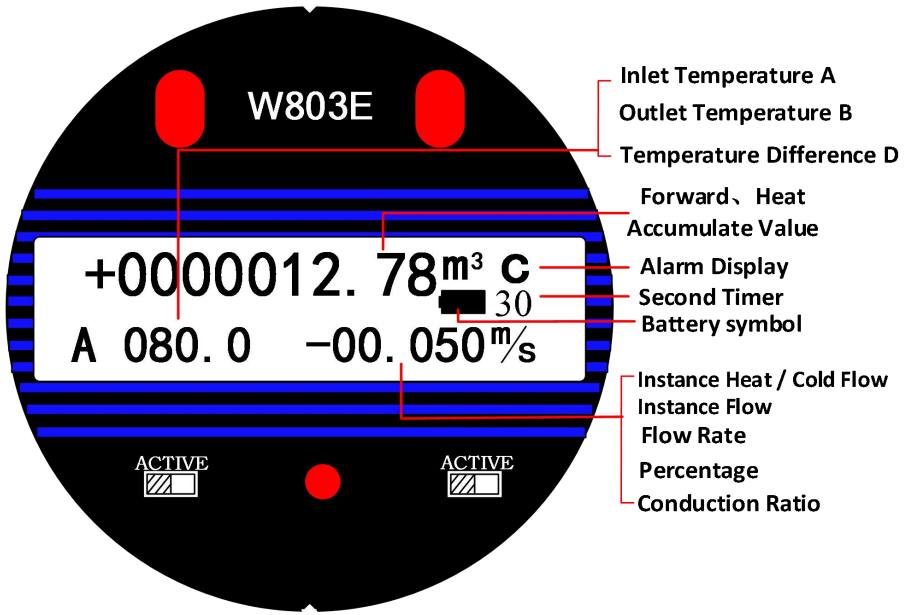

Fig3.1c W803E Converter LCD (Flow + Temperature Mode)

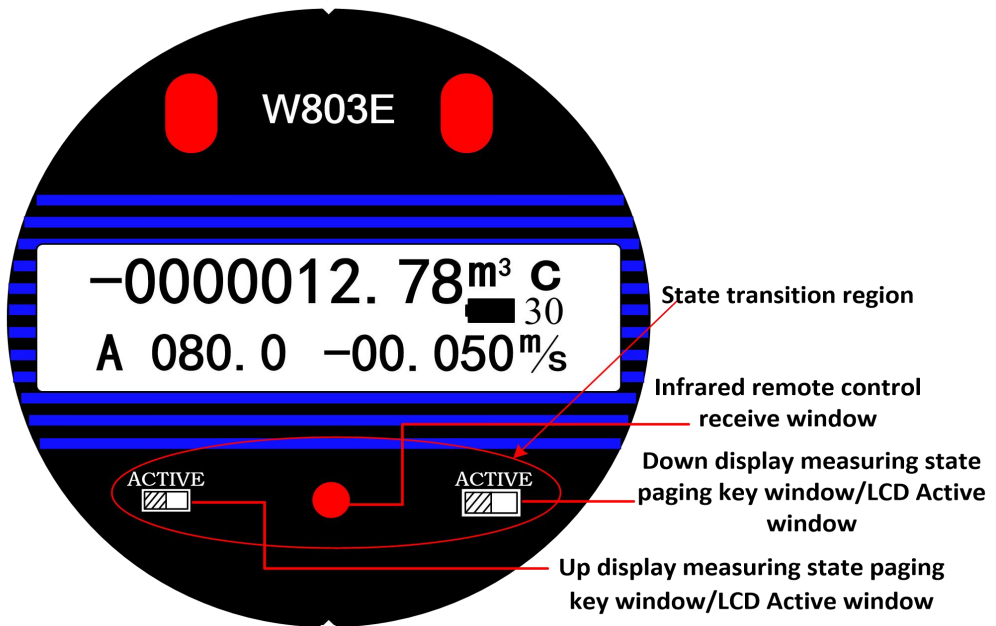

Fig. 3.2 W803E magnetic key operational position



- Power -test mode to measurement mode
- Menu -test mode to parameter settings
- Enter -parameter settings to all levels of the menu
- Return -parameter settings back to the next higher level menu
- Left -cursor moves left
- Right -cursor moves right

Fig 3.3 W803E infrared remote control display and operation

3.1 Meter Mode

Test mode: Supply power to the converter, the instrument get into the test mode (LCD middle row no battery symbol on the right side). The converter can output pulse signals to complete the machine calibration or change the converter parameters. After entering the meter calibration mode, without any operation, 3 minutes automatically transferred into the measurement model; If there are any operation, stop the operation to maintain after 3 hour examining mode, and then transferred into measuring instrument automatic mode.

The transition from the measurement mode to test mode is described below:

- 1) First trigger the right-down reed pipe with the magnet of the infrared remote control until the position of Percentage, move away the magnet;
- 2) Then trigger the left-down reed pipe until the LCD doesn't display, and then move away the magnet. Wait for a moment, the state has changed to test mode already.

Measurement mode: measurement mode is applied when the converter is in use(there is battery symbol on the right side of the LCD). Under measurement mode, converter can complete the measurement of flow, velocity and empty pipe parameter etc.It can also output pulse signal and RS485 or GRPR communication via infrared transmission.

Sleep mode: Because the meter is factory sealed, the converter is set sleep mode for

power saving. The converter has no display, no output and little power consumption . So the users should wake up the converter as 3.2.

LCD shutdown mode: In order to reduce power consumption and prolong the life of the converter, the converter has LCD shutdown function. The default LCD shutdown function is allowed when the converter is out of the factory. When the converter works at 00:00, the LCD will automatically turn off without affecting the normal measurement and communication functions of the converter. If you want to activate the LCD, you only need to trigger either of the two flip keys of the converter with the remote magnet, as shown in Figure 3.2. If the user does not want to use this function, the LCD closing function can be set to no use.

3.2 Meter Wake-up

When need to wake up the instrument, users can use two infrared remote controllers (following abbreviation remote control) to trigger the two down reed pipe at the same time until appear the picture below. Press the return key of the remote control. After the converter wake up, the “Meter Dormancy” become “00000” automatic. If set the converter to sleep, set the “Meter Dormancy” to 23130.

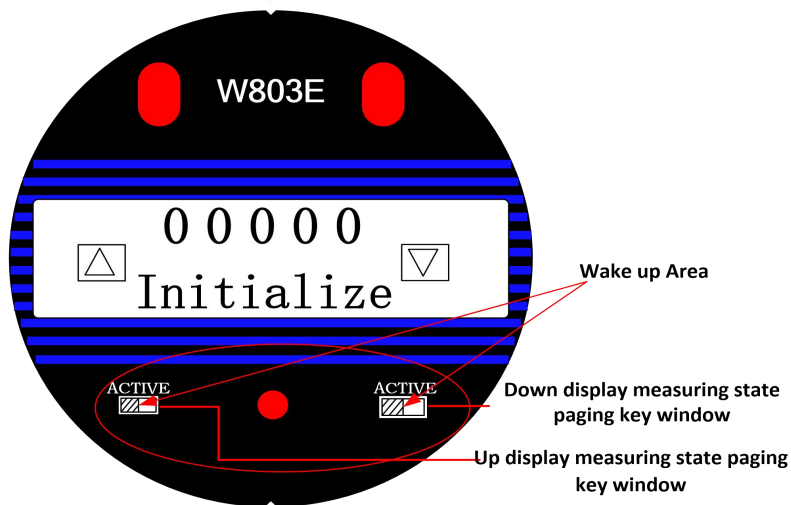

Note: The internal clock doesn't work when the meter dormant, after wake up the instrument, the user must reset the meter time parameter.

3.3 Sleep Mode Setting

If the user intends to set the meter into sleep mode, use the remote control to set the

converter menu 'Operate Mode' sub menu 'Meter Dormancy' password to 23130 and go back to test mode (On the right, it has LCD battery symbol in middle row).

3.4 Change between Measurement Mode and Test Mode

3.4.1 Measurement Mode into Test Mode

In the measure mode, use the magnet of the remote control to scan the state conversion window into the test mode (there is no battery symbol on LCD, and seconds timer accumulate once per second).

3.4.2 Test Mode into Measurement Mode

When need to enter measurement mode under test mode, just need to aim at the 'remote control window' and press 'power' key(there is battery symbol in the middle of the LCD).

3.5 Parameter Setting

3.5.1 Parameters Setting and Remote Control Operation

If set or modify parameters, make sure the meter is under parameters setting mode. In the test mode, press "Menu" to enter the password "00000". After entering the password,press "Enter " to enter "Parameters Set" function selection display, then press "Enter " again to enter the main operating menu. If intend to change the main menu, press "+" or "-". Refer to the figure below:

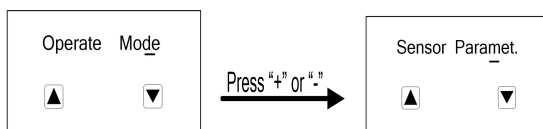

Fig. 3.4

If intends to set sub menu parameter, move cursor to press "Enter" and enters sub menu of the present main menu. If you want to return to the higher level menu or the calibration model, need to press the return key.

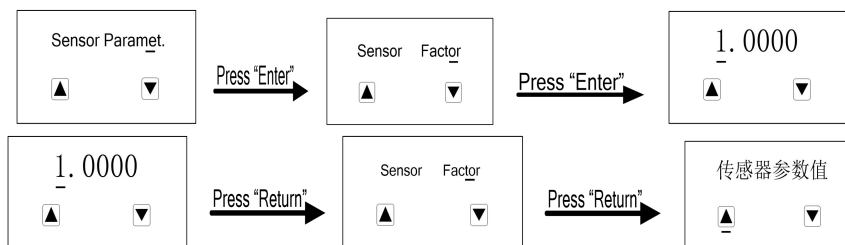

Fig. 3.5

3.5.2 Function Selection Display

Press “Menu” to enter the password “00000”. After enter the password, press “Enter ” to enter the function selection display, and press “+” to select. There are five functions to select:

Table 3.1

Parameter Number	Function	Comments
1	Parameters Set	Select the function to enter parameters setting
2	Clr Total Rec	Select the function to clear total record
3	FWD Flow Total	Select the function to record the forward flow total of 120 months. (Storage by month and the year’s end separately) (Number=Mantissa of the year×12+month) For example: year:2019 month:10 Number=9×12+10=118
4	REV Flow Total	Select the function to record the reverse flow total of 120 months. (Storage by month and the year’s end separately) (Number=Mantissa of the year×12+month) For example: year:2019 month:10 Number=9×12+10=118
5	Heat Total Rec	Select the function to record heat total of 120 months. (Storage by month and the year’s end separately) (Number=Mantissa of the year×12+month) For example: year:2019 month:10 Number=9×12+10=118
6	Error Record	Select the function to record error record of 24 month in “Flow+Temperature” mode.
7	Date Time Set	Set year、month、day、hour、minute、second, and press “C” on remote controller to convert year、month、day and hour、minute、second
8	Modificat Record	Select this function to record the modificat record (00-31), include:Flow Zero、Sensor Factor、Meter Factor、Meter Correct
9	Backup Paramets	Reserve
10	Recovery Paramet	Reserve

3.6 Clr Total Record

Step 1: According to then method of “3.5 Parameter Setting” to set “Clear Total Key”and back to test mode.

Step 2: In the test mode, press “Menu”key. (Meter version will be displayed for 5s,and then “ Parameters Set” is displayed.)

Step 3: After enter the password,press “+”, “Clr Total Rec ” is displayed.

Step 4: Press”Enter”key ,input the “Clear Total Key” set in step 1 and press “Enter”key, the meter displays “00000”, Clear Total Record is done.

Step 5:Press “Return”, meter is back to test mode.

Remarks:

《Clr Total Rec》 +1: clear heat or cold total under current mode.

《Clr Total Rec》 +3: clear work time.

《Clr Total Rec》 +4: clear 120 months flow and heat monthly record.

《Clr Total Rec》 +7: clear 24 error record.

Note:

1. The factory set of the meter is sleep mode (the LCD is not lighted), users need to use remote control to wake up the meter for normal use (refer to 3.2); When using the meter, please set the time to affect the use.
2. When the meter is waked up, the meter is in test mode. Meter correction or parameters setting can be done in the test mode. Measurement or communication must be done under measurement mode.

4 Converter Wiring

4.1 Definition of Signal Line

W803E battery powered converter has two groups of wiring: signal line group and excitation line group. Two groups are connected to different sensors separately. Pay attention to avoid any possible damage to meters because of incorrect wiring.

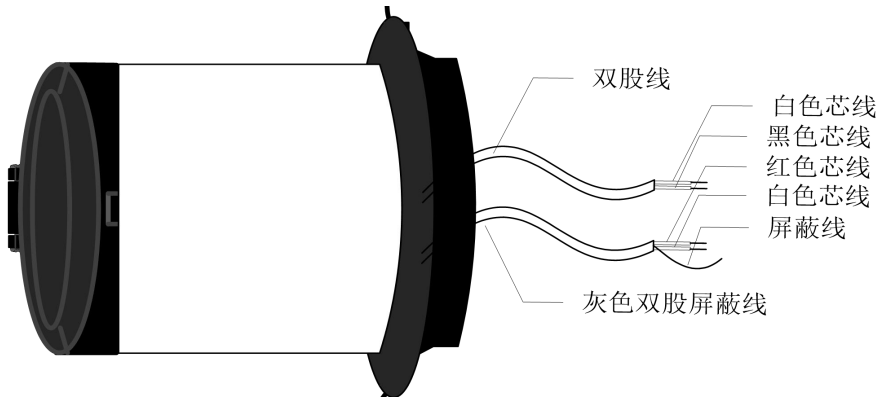

Fig. 4.1 W803E Signal Line

Signal lines are signed as follows :

Black twin plastic wire:	White core wire	} Connect with excitation
	Black core wire	
Gray twin shielding wire:	Connect the red core wire to "signal 1"	
	Connect the white core wire to "signal 2"	
	Connect the shield wire to "signal ground"	

4.2 Converter Waterproof Interface Definition and Wiring

4.2.1 Converter Waterproof Interface Definition

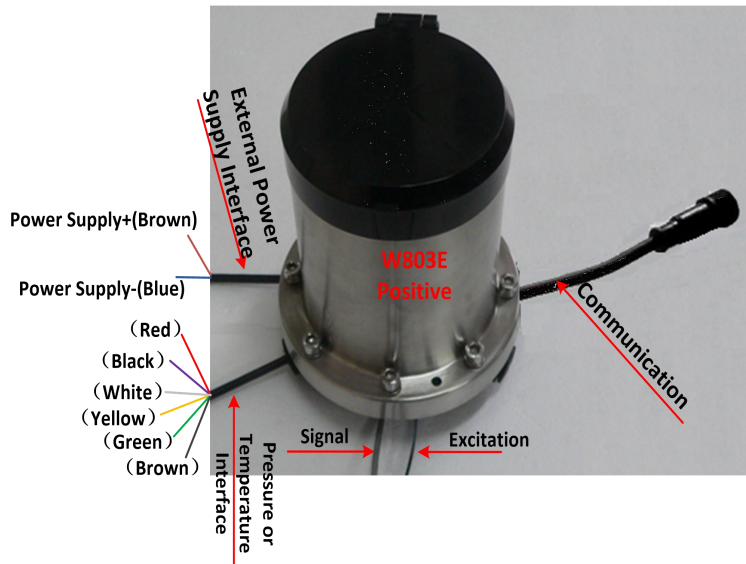

Fig. 4.2a W803E Converter Waterproof Interface Definition

Communication Interface: This port is a standard reserved port. Users can connect different accessories to realize different functions such as RS485 communication, 4-20mA + current loop communication etc.

Pressure measurement Interface(four core wire):

- Red Wire — Power Supply+
- White、 Black Wire — Suspension
- Yellow Wire — Pressure signal+
- Green Wire — Pressure signal-
- Blue Wire — Power Supply-

Pressure measurement Interface(six core wire):

- Red Wire — Power Supply+
- White、 Black Wire — Suspension
- Yellow Wire — Pressure signal+
- Green Wire — Pressure signal-
- Blue Wire — Power Supply-

Temperature measurement Interface(six core wire):

- Red Wire — Inlet thermal resistance negative
- Black Wire— Inlet thermal resistance negative
- White Wire— (short with the yellow wire) Inlet thermal resistance positive
- Yellow Wire—(short with the white wire)Inlet thermal resistance positive
- Green Wire—Outlet thermal resistance negative
- Blue Wire—Outlet thermal resistance negative

Power Supply Interface (two core wire):

- Brown Wire —External power supply+
- Blue Wire—External power supply-

4.2.2 Converter Pressure Measurement Interface and Pressure Sensor Wiring

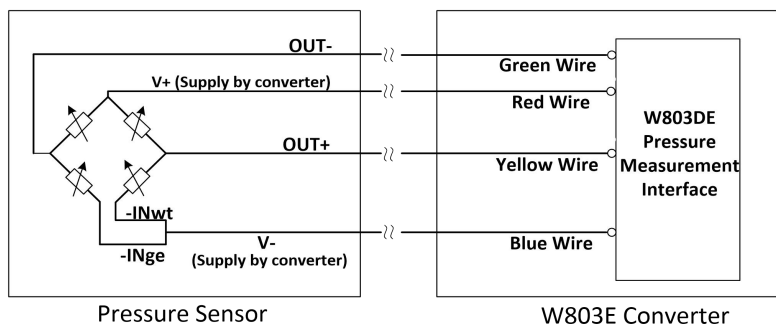

4.2.3 Converter Temperature Measurement Interface and Temperature Sensor

Wiring

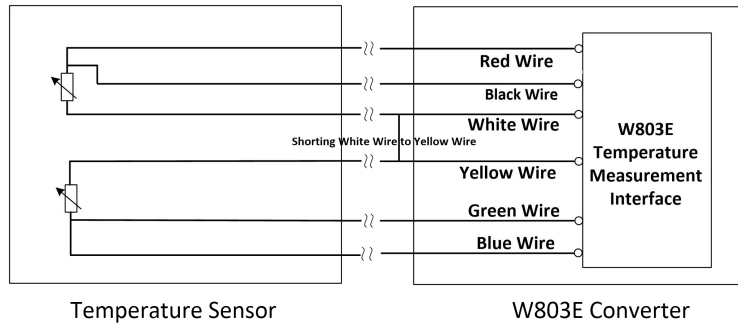

4.3 Converter Assembled Grounding Requirements

First, use $\Phi 20$ copper, cut to 1700mm long (can be extended if necessary) to make ground nail buried 1500mm (Note: When buried nails, nail tips in spreading a layer of wood chips carbon, then pour brine);

Second, solder 4mm^2 copper wire to the ground nail, and finally ground to the sensor flange, grounding rings, pipe flanges, refer to Fig. 4.3.

Note: stainless steel is required to fixed ground screw, spring washer, and flat washer.

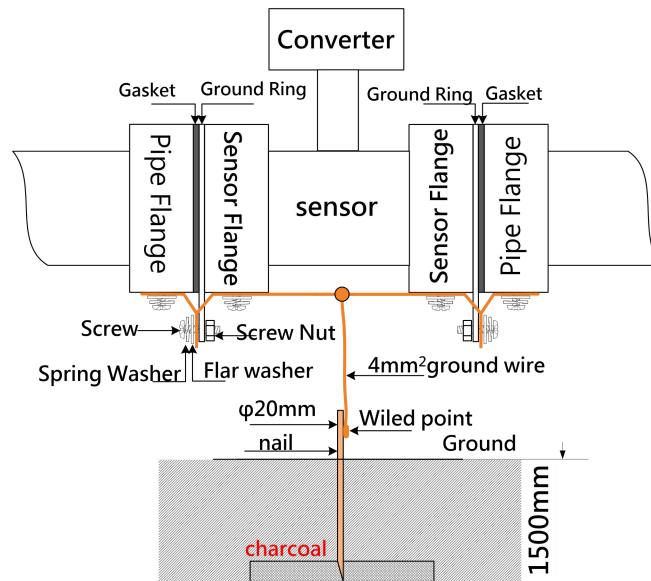

Fig. 4.3 Converter Grounding Schematic

4.4 Flow Test

4.4.1 Pulse Output Wiring

For need for the flow test, W803E has pulse output signal to output pulse per unit volume. In order to ensure good seal, the pulse output interface is calibrated by infrared calibration box. When doing the user calibration, refer to the wiring diagram below.

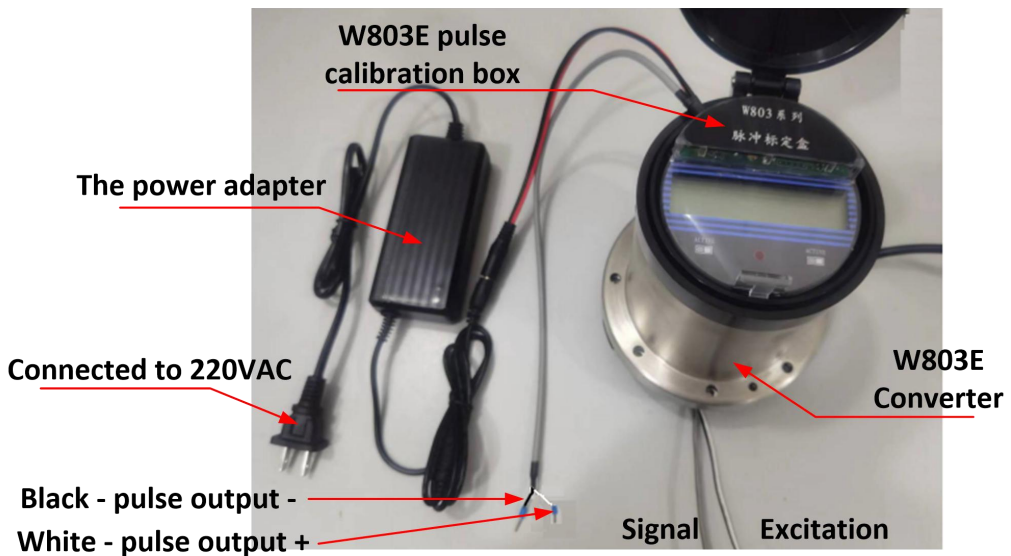

Fig.4.4.1 Connection between pulse output and other devices in demarcate state

4.4.2 Pulse Output and Calibration System Connection

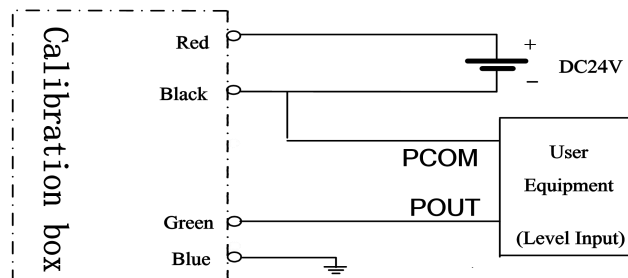

Fig. 4.4.2 Pulse Output and Calibration System Connection

4.4.3 Pulse Output Parameter Setting

- Users need to set pulse output rate in the sub menu “Pulse Factor” when calibrate. And when the pulse width is 0.05mS, the maximum pulse is 10000, so the pulse rate need low than the maximum pulse to result in calibration error.

For example: use DN100 flow meter, when the flow rate is 10m/s, the flow is 282.74m³/h. If the pulse output equivalent is 0.01L, there are 7854 pulses output per second.

- Pulse output rate should not be selected too high to avoid approaching the upper limit of the output rate, causing the output pulse loss and affecting the accuracy of the instrument calibration.
- To avoid counting synchronization error between calibration system and calibrated meter, W803E battery powered converter requires calibration count each time is longer than 4 minutes.

5 Meter Parameter

The parameters of W803E battery powered converter are: Operate Mode, Flow Parameters, Output Parameters, Sensor Parameter, Linearization, Temperature Parameters, Communication, Factory Adjust, Total parameter and Pressure Parameter. The definitions of the parameters are as below:

5.1 Operate Mode

5.1.1 Operate Mode S.

There are three kind of mode: Flow only, Flow+pressure, Flow+Temperature. Users can choose according to needs.

5.1.2 Interval Time

In the measurement mode, meter measurement interval time can be set from 2 seconds to 30 seconds (If the setting is less than the 15S, working an hour later, meter setting will automatically become 15S).

5.1.3 Meter Dormancy

When the sleep password is "23130", the instrument will start the sleep mode.

5.1.4 Measure Mode

It provide for temperature meter users with two modes of heat measurement and cold measurement.

5.1.5 LCD Time Sleep

In order to reduce the power consumption of the instrument and prolong the service life of the instrument, the converter has the function of automatically closing the LCD when the measuring state works to 00:00. The LCD shutdown does not affect the normal measurement and communication function.

When the option is "Enable", it has the function of LCD closing; when the selection is

“DISABLE”, the LCD closing function is canceled.

5.1.6 Backups Enable

Reversed.

5.1.7 SD_Card Enable

Reversed.

5.1.8 Humidity Enable

Reversed.

5.1.9 Bi_Direct Enable

When ‘Bi_Direct Enable’ is set ‘DISABLE’, both forward and reverse flow of the converter cooperate with ‘FWD Sensor Fact’ and ‘FWD.Linearizati’;

When ‘Bi_Direct Enable’ is set ‘ENABLE’, forward flow of the converter cooperate with ‘FWD Sensor Fact’ and ‘FWD.Linearizati.’, and reverse flow of the converter cooperate with ‘REV Sensor Fact’ and ‘REV.Linearizati’.

The default setting of Bi_Direct Enable is ‘DISABLE’, so users should set the FWD Sensor Fact and FWD Linearization.

5.2 Flow Parameters

5.2.1 Sensor Size

Sensor size scope of W803E battery powered electromagnetic converter is 3 to2100 mm.

3,4,5,6,8,10,12,15,20,25,32,40,45,50,55,60,65,70,75,80,85,90,95,100,125,150,200,250,300,320,350,400,450,500,550,600,650,700,750,800,850,900,950,1000,1100,1200,1300,1400,1500,1600,1700,1800,1900,2000,2100

5.2.2 Flow Unit

Flow Units are L/h、L/m、L/s、m3/h、m3/m、m3/s、ukg/h、ukg/m、ukg/s、usg/h、usg/m、usg/s、kg/h、kg/m、kg/s、t/h、t/m、t/s. User can select the unit according to actual status.

5.2.3 Flow Range

Flow range setting means upper limit flow value setting, and lower limit flow value is set “0” automatically.

5.2.4 Flow Direction

When doing debugging, if the flow direction is not consistent, users do not have to change the excitation line or signal line connection, and just reset the flow direction parameters.

5.2.5 Flow Zero CRC

Make sure the sensor is full and the fluid is in stationary state when doing the flow

zero-point correction. Flow zero-point is shown as velocity of flow, mm/s. Zero-point correction displayed as below:

$$\begin{array}{c} 32 \quad \pm 000.0 \\ \triangle \text{ FZ} = +0000.0 \quad \nabla \end{array}$$

Upper large characters: corrected flow zero-point.

Lower small characters: FZ means measured zero-point;

When FZ display is not "0", do correction to make FZ display to "0". Note: if correct upper line character and FZ increases, change the "+, -" in upper line to make sure FZ display to be zero.

The corrected flow zero-point is the compound value of sensor, and shall be recorded in sensor list and label. The unit is mm/s, and the sign is in opposite with corrected value.

5.2.6 Flow Cutoff

Small signal elimination point setting is showed by flow. When applied small signal elimination, the flow, gross, pulse output are also eliminated, only the velocity of flow is displayed.

5.2.7 Flow Filer Time

Long measured damping time can enhance the stability of flow display and output digital, and is applicable for cumulative add up of pulse flow. Short measured damping time means quick respond to measurement, and always apply in production control. Measured damping time setting is by choosing. (Damping time can only be applied in test mode.)

5.2.8 Reverse Flow En

W803E converter has reverse flow output disable function, when 'DISABLE', no output display of the flow, pulse and accumulated gross, only the flow rate display; When the 'ENABLE', converter works properly.

5.2.9 Starting Value

In the measurement state, in order to quickly track and measure the drastic change of flow, the instrument judges the change of flow velocity. When the change of flow velocity is greater than the threshold of flow frequency measurement, the instrument starts fast tracking measurement to ensure the accuracy of measurement. When the flow rate changes less than the flow frequency measurement threshold, the instrument is measured according to the interval measurement time interval.

5.2.10 Heat Display

This function is temporarily reserved.

5.2.11 High/Low Alm. Limit

The parameter of high/low alarm limit is calculated by flow ,and the parameter is set by numerical setting. When the value of flow is higher or lower than the value of setting value,

the high or low limit is alarm. High or low alarm is transmitted in communication, no alarm signs are displayed and on alarm output is given.

5.2.12 Fluid density

When the flow unit is set to the quality unit kg/h, kg/m, kg/s, t/h, t/m and t/s, this parameter is worked, the maximum setting can be 5.9999, no unit display, when unit setting is kg, the unit of density is kg/L, and the T unit density is t/ m³.

5.3 Output Parameters

5.3.1 Pulse Out Enable

It works in the measurement state. If “Forbidden”, pulse output function is off. If “Allowance”, pulse output function is on.

5.3.2 Pulse Unit

There are two output pulse units: m3 , L,ukg,usg.

5.3.3 Pulse Factor

Pulse factor is pulse equivalent, and the range is from 0.0001 ~ 5.9999 , Output pulse equivalent unit is in consistence with the selected pulse output type, and used to pulse output of test mode.

5.3.4 Pulse width

When the pulse output is low level effective. The scale of pulse width is from 0.05 ms to 12.5ms. The users set the parameters based on their needs.

Table 2

No.	Pulse-width(ms)	Num of the maximum pulse(p/s)
1	0.05	10000
2	1	500
3	10	50
4	12.5	40

5.4 Sensor Parameters

5.4.1 FWD.Sensor Fact/ REV Sensor Fact

Sensor factor is electromagnetic flow meter calibration factor. The factor obtained from the actual calibration, and stenciled onto the sensor plate. Users shall input the factor factor into W803E converter parameter.

Note: this parameter should cooperate with ‘Bi_Direct Enable’. See in the 5.1.9

5.4.2 Excitation Time

There are two excitation modes to select: TYPE1、TYPE2。 Small diameter sensor excitation system exciting small caliber, TYPE1 should be selected. Large diameter sensor excitation system exciting large caliber, TYPE2 should be selected. In use, first select excitation TYPE1, if the meter displays flow rate zero is too high or SYS, then select TYPE2. Note: excitation mode shall be in consistent with calibration mode.

5.4.3 Sensor Coding

Sensor encoder is used by the factory to record the sensor.

5.4.4 Empty Pipe Value

W803E measures the resistance between the two electrodes of the sensor to determine whether the pipe is empty. In the measurement mode, when the pipe is full, observe the fluid measured resistance value (R%), then take 1.5 to 2 times of the measured values to set the empty pipe alarm threshold . When the pipe is empty, the resistance between the electrodes increases, if the threshold is exceeded, empty pipe alarming is triggered.

5.4.5 Empty Zero CRC

User can do empty pipe zero-point correction. When doing the calibration, make sure the senior is full. Empty pipe zero-point correction displayed as below:

0	0	0	0	0		
MZ	=	+	0	0	0	15

Upper large characters: calibrated empty pipe zero-point.

Lower small characters: MZ means measured zero-point;

According to the actual measured conductivity R%, do correction to make MZ=5 – 10.

Note: if increase upper line character and MZ decreases.

5.4.6 Empty Range CRC

User can do full pipe zero-point correction when the conductivity R% is small. When doing the calibration, make sure the senior is empty. Full pipe zero-point correction displayed as below:

1	0	0	0	0		
MR	=	0	0	1	0	7

Upper large characters: calibrated full pipe zero-point.

Lower small characters: MR means measured zero-point;

Increase upper line character and MR decreases. Decrease upper line character and MR increases. User can correct MR to proper value based on actual needs, the conductivity obtained in empty pipe is actual corrected MR.

5.4.7 System Alarm Ena

The converter has the function of system alarm prohibition. When 'DISABLE', the alarm function of the system is canceled. When 'ENABLE', the instrument has the function of system alarm.

5.4.8 Excit. Value Set

(this parameter is related to the actual model)

There are three kinds of excitation current: Excit:1、Excit:2、Excit:3. Users should choose the excitation current according to the resistance of the sensor. Seen in the 6.1 Sensor Matching Requirements.

5.5 FWD or REV Linearization

5.5.1 Linearizati. Ena

The parameter is used to select whether meter linear correction will do. If 'DISABLE', correction will not do; if 'ENABLE', correction will do.

5.5.2 FWD or REV Correct Po. or Target Val.1-4, FWD or REV End Velocity

Details refer to Annex 2.

Note: this parameter should cooperate with 'Bi_Direct Enable'. See in the 5.1.9.

5.6 Temperature Parameters

5.6.1 Heat Unit

There are four heat unit for users: GJ、MJ、KWH、MWH.

5.6.2 Sensor Position

If the heat meter is installed at the heating pipe inlet, select "inlet". If the sensor is installed at the outlet, select "outlet". Remember: if the parameter selection is inconsistent with the actual installation, the calculation error will be caused.

5.6.3 Temperature Filter

Long filtering time can improve the display stability of instrument temperature. short filtering time shows fast response speed and is suitable for production process control. The choice of measuring time is chosen

5.6.4 Ent.T、 Out.T Zero CRC,Ent.T、 Out.T Range CRC

The connection method of Pt1000 thermal resistance is three wire bridge. See the Appendix 6 in detail.

5.6.5 Pressure Range

Battery power supply heat meter is set at 0.6MP and 1.6MP pressures according to the industry standard CJ128-2007 of the People's Republic of China.

5.6.6 Ent.Temperature calibrate、 Out.Temperature calibrate

This coefficient is used to correct the difference between the temperature of a certain temperature point and the standard temperature. It does not affect the overall temperature linearity after correction. It is mainly used when there is an error in the field thermal resistance indication. Only in the measurement state.

5.7 Communication

5.7.1 Comm Address

Communication address means address range when doing data communication. The address range is from 01 to 199 and address 0 is reserved.

5.7.2 Communication Rate

The scale of communication rate is:1200、 2400、 4800、 9600、 14400.

To save power consumption: the factory communication rate is fixed at 9600. If other communication rates are used, please contact the manufacturer.

5.7.3 Communicat. check

Converter marking communication mode is no parity of standard MODBUS check mode. Users can choose odd parity or even parity as needed.

5.7.4 Communicat.Gap

Reversed.

5.7.5 IrDA Data Type

There are two types of infrared data: IrDA pulse mode (default) and IrDA total mode. When the IrDA pulse mode is selected, the instrument is calibrated according to the pulse mode; when the IrDA total mode is selected, the instrument is calibrated by communication with the cumulative verification system.

5.8 Factory Adjust

5.8.1 Language

There are Chinese and English in W803E converter for users.

5.8.2 Meter Factor

Factory calibration factor the special factor of sensor-made-factory and the factory use this factor to unite W803E converters to make sure all the Meters can interchange by 0.1%.

5.8.3 Meter Correct

Used by the factory.

5.8.4 Meter Code 1-4

Converter coder records the time the converter leaves the factory and the number.

5.8.5 Multiplier

Flow, speed and output are calculated by this coefficient if this coefficient isn't 1.0000.

5.9 Total Parameter

5.9.1 Flow Total Unit

10 bit calculator is applied and the upper limit is 4294967295.

Flow Integrating Units are:	0.001L	0.010L	0.100L	1.000L
	0.001m3	0.010m3	0.100m3	1.000m3
	0.001ukg	0.010ukg	0.100ukg	1.000ukg
	0.001usg	0.010usg	0.100usg	1.000usg
	0.001kg	0.010kg	0.100kg	1.000kg
	0.001t	0.010t	0.100t	1.000t

5.9.2 Heat Total Unit

10 bit calculator is applied and the upper limit is 4294967295.

Heat Integrating Units are:	0.001GJ	0.010GJ	0.100GJ	1.000GJ
	0.001MJ	0.010MJ	0.100MJ	1.000MJ
	0.001KWH	0.010KWH	0.100KWH	1.000KWH
	0.001MWH	0.010MWH	0.100MWH	1.000MWH

5.9.3 Clear Total Key

User can use upper level password to set total clearing password. Enter function selection menu, press the page key to enter into total clearing menu to set the total clearing password, and complete the total clearing.

5.9.4 Forward and Reverse Total High and Low

Total high and low bit setting can change the flow total value which is used in meter maintenance and replacement. User use high level password to change the flow total value and generally can't exceed the maximum value of counter (3999999999).

Correct Factor

0.7500

PR=01900

5.10.5 Press. Hi/Lo. Alarm

These two parameters can be set with an adaptive pressure value. When the instant pressure is higher than the set value as the equipment working, the pressure high limit is alarm; on the contrary, the pressure low limit is alarm. Pressure high or low alarm is transmitted in communication, no alarm signs are displayed and on alarm output is given.

6 Performance Indicators

- Environmental Temperature: -10°C -- 50°C
- Relative Humidity: $\leq 95\%$
- Outer Covering Protection Level: IP68
- Flow Speed Measurement Range : 0-15m/s
- Conductivity: Clean water >20 $\mu\text{s}/\text{cm}$
- Measuring Diameter: DN3---DN2100
- Matching Accuracy Class: 0.5
- Measurement Parameter: instantaneous flow, instantaneous flow rate
- Record Parameter: accumulated total Flow
- Detection and Alarm Parameters: Fluid empty pipe detection alarm, excitation current detection alarm
- Test mode Output Signal: Unit volume flow pulse
- Communication Mode: RS485 (modbus protocol), GPRS
- Battery Working Time

Table 6.1.1 Corresponding Table of Battery life and Interval Measurement Time

(Excitation TYPE 2)

Cycle Measuring Time	50mA Excitation Use Time	20mA Excitation Use Time
30S	74months	103months
25S	62months	87months
20S	49months	69months
15S	37months	52months
14S	34months	48months
13S	32months	45months

12S	30months	42months
11S	27months	38months
10S	24months	34months
9S	21months	31months
8S	18months	27months
7S	15months	24months
6S	13months	21months
5S	10months	17months
3S	7months	10months

Table 6.1.2 Battery Life Factor Corresponding Excitation Mode

Excitation Mode	Mode 1	Mode 2
Battery Life Factor	1.24	1.0

When the sensor has large diameter, the corresponding excitation cycle is long (see excitation mode parameter), therefore there is more power consumption.

6.1 Sensor Matching Requirements

Please select according to the actual module of flowmeter.

6.1.1 Adjust excitation current by hardware

(this applies to software other than version 47)

- For 20mA, sensor excitation coil resistance: 70 to 100 Ω (two coils in series)
- For 25mA, sensor excitation coil resistance: 45 to 70 Ω (two coils in series)
- For 35-50mA, sensor excitation coil resistance: 35 to 45 Ω (two coils in series)
- Sensor flow signal strength: 50 to 100 μV (1m/s)

6.1.2 Adjust excitation current by software

(this applies to software version 47)

- For Excit:1, sensor excitation coil resistance: 30 to 50 Ω (two coils in series)
- For Excit:2, sensor excitation coil resistance: 51 to 60 Ω (two coils in series)
- For Excit:3, sensor excitation coil resistance: 61 to 90 Ω (two coils in series)
- Sensor flow signal strength: 50 to 100 μV (1m/s)

Note: Special note is necessary to order excitation coil resistance!

Explain: When doing the flow correction, if corrected sensor factor is around 1.0000, it is indicating that the flow sensor signal strength meets the requirements. If corrected sensor factor is greater than 1.0000, it is indicating that flow sensor is with low sensitivity. If corrected sensor factor is less than 1.0000, it is indicating that the flow sensor is with high

sensitivity. If flow sensor with high sensitivity, stability and conducive of the flow meter measurement accuracy is better.

6.2 Installation dimension diagram

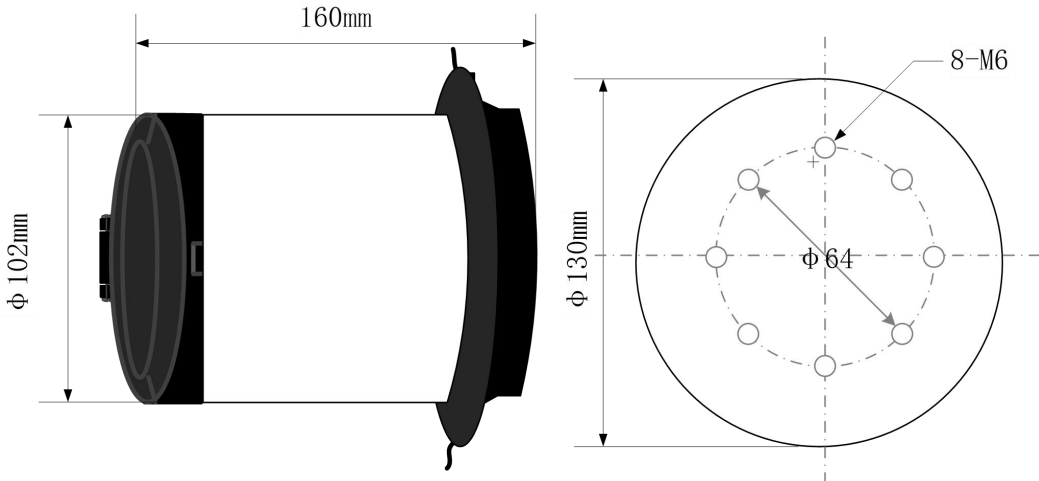

fig. 6.2.1 Mounting Drawing

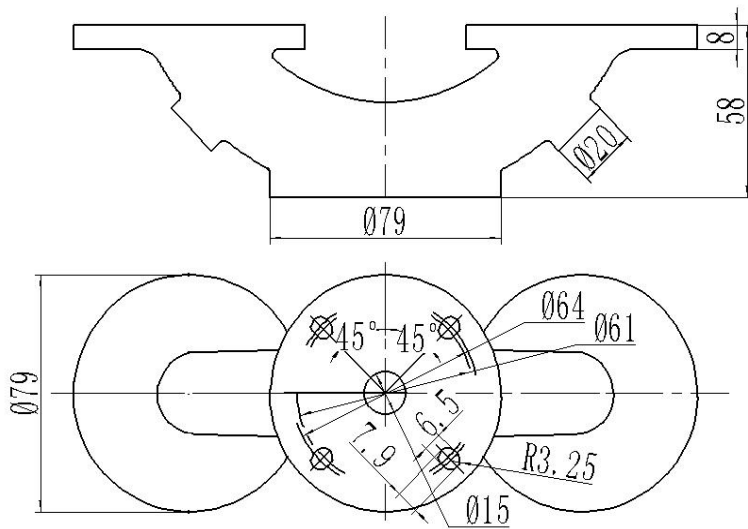

Fig.6.2.2 One flange installation size chart

7 Alarming Information

There are several kinds of alarming shown: S—system alarming, M—empty pipe alarming, C—small signal cut alarming, A/B—temperature break alarm, P— pressure alarm, short-excitation short circuit to ground alarm, BAT.LOW—low battery alarm.

If S displays, it is possible that converter exciting breaks or converter excitation frequency

mode selection inappropriate.

8 Error Disposition

8.1 No Display

- * Check whether the power is on;
- * Check whether the power voltage meets the requirement

8.2 Excitation Mode Alarming

- * Check whether excitation wiring EX1 and EX2 is open circuit
- * Check whether the total resistance of the excitation coil of the sensor matches the excitation current of the converter;
- * If the items above are in normal, then the converter is malfunctioned

8.3 Empty Pipe Alarming

- * Check whether the fluid is full of the sensor pipe
- * Connect the signal3 (white line, red line and the shield line) to short circuit, if the empty pipe alarming "Empty Pipe" disappeared, the meter is in normal condition; otherwise, the error may be caused by low fluid conductance, wrong setting of empty pipe threshold or range.
- * Check whether the signal wiring is correct
- * Check whether the sensor pole is in normal condition

If the flow is zero, the displayed conductance ratio shall be less than 100%

If there is liquid in pipe, the resistance between white line and red line to shield line shall be less than 50k Ω . (If the medium is water, it is better to use pointer multi-meter to do the test and there is charge and discharge during the testing.)

8.4 Flow Measurement Inaccurate

- * Check whether the liquid is full of sensor pipe
- * Check whether the signal cable is in normal condition
- * Check the sensor parameter and zero-point is set by sensor label or factory calibration

8.5 Remote control Key Failure

If the buttons are unresponsive when aligned remote control to infrared tube, the power button battery insides the remote control may be low. The remote control can be detached to measure button battery voltage. If the value is lower than 2.7V, the remote control can't work properly. Then button battery needs to be replaced.

Solemnly declare: the manual is applied to common software and if the content is not in consistent with the converter, refer to the actual product.

Annex 1 Parameter Setting Overview

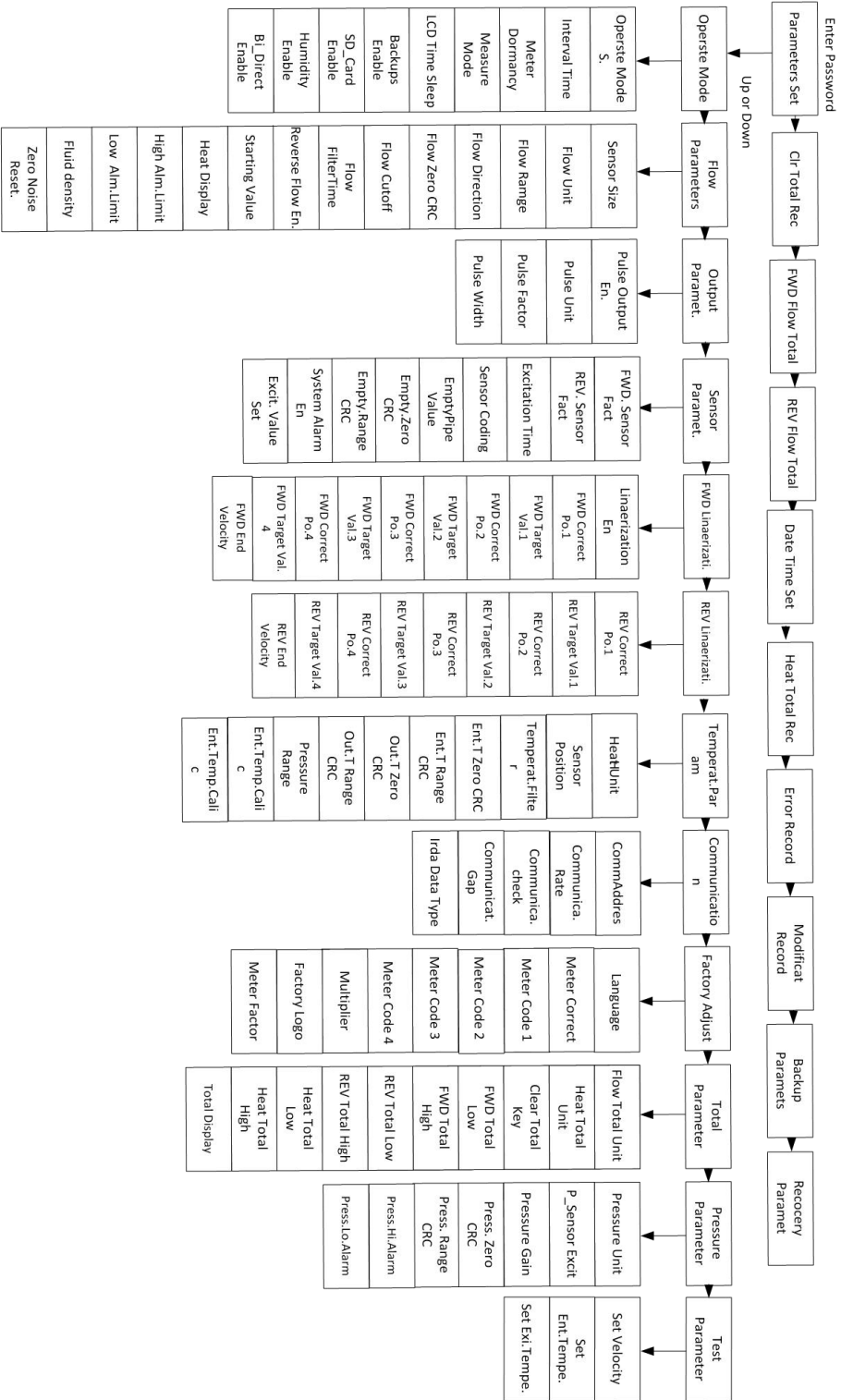

Menu List

Code	Parameters	Set	Content	Password Level
I	Operate Mode			
1	Operate Mode S.	Select	Flow only 、 Flow+Pressure、 Flow+Temperature	1
2	Interval Time	Select	2~30SEC	1
3	Meter Dormancy	Set Count	0~59999	1
4	Measure Mode	Select	Measure Heat、 Measure Cold	1
5	LCD Time Sleep	Select	Enable、 Disable	1
6	Backups Enable	Select	Enable、 Disable	1
7	SD_Card Enable	Select	Enable、 Disable	1
8	Humidity Enable	Select	Enable、 Disable	1
9	Bi_Direct Enable	Select	Enable、 Disable	1
II	Flow Parameter			
1	Sensor Size	Select	3~2100mm	1
2	Flow Unit	Select	L/s、 L/m、 L/h、 m ³ /s、 m ³ /m、 m ³ /h、 ukg/s、 ukg/m、 ukg/h、 usg/s、 usg/m、 usg/h、 kg/h、 kg/m、 kg/s、 t/s、 t/m、 t/h	1
3	Flow Range	Set Count	0~65535	1
4	Flow Direction	Select	FORWARD、 REVERSE、 ALL FORWARD、 ALL REVERSE	1
5	Flow Zero CRC	Set Count	0~±9999	1
6	Flow Cutoff	Set Count	according to flow	1
7	Flow FilterTime	Select	3~30Sec	1
8	Reverse Flow En.	Select	Enable、 Disable	1
9	Starting Value	Set Count	0~59.999m/s	1
10	Heat Display	Select	Reserved	1
11	High Alm.Limit	Set Count	0~65535	1
12	Low Alm.Limit	Set Count	0~65535	1
13	Fluid density	Set Count	0~1.9999	1
14	Zero Noise Reset.	Select	Enable、 Disable	1
III	Output Parameters			
1	Pulse Output En.	Select	Enable、 Disable	1
2	Pulse Unit	Select	m ³ 、 Ltr、 ukg、 usg	1
3	Pulse Factor	Set Count	0.0000~ 5.9999	1
4	Pulse Width	Select	0.05~12.5ms	1

IV	Sensor Paramet.			
1	FWD. Sensor Fact	Set Count	0.0000~5.9999	1
2	REV. Sensor Fact	Set Count	0.0000~5.9999	1
3	Excitation Time	Select	TYPE1、TYPE2	1
4	Sensor Coding	User set	Factory YAER、MONTH (0~59999)	1
5	EmptyPipe Value	Set Count	0~59999	1
6	Empty.Zero CRC	Set Count	0~19999	1
7	Empty.Range CRC	Set Count	0~59999	1
8	System Alarm En.	Select	Enable、Disable	1
9	Excit. Value Set (for version 47)	Select	Excit:1、Excit:2、Excit:3	1
V	FWD.Linearizati.			
1	Linearizat. Ena	Select	Enable、Disable	1
2	FWD Correct Po.1	User set	According to Velocity	1
3	FWD Target Val.1	User set	According to Velocity	1
4	FWD Correct Po.2	User set	According to Velocity	1
5	FWD Target Val.2	User set	According to Velocity	1
6	FWD Correct Po.3	User set	According to Velocity	1
7	FWD Target Val.3	User set	According to Velocity	1
8	FWD Correct Po.4	User set	According to Velocity	1
9	FWD Target Val.4	User set	According to Velocity	1
10	FWD End Velocity	User set	According to Velocity	1
11	Speed Value 5	User set	According to Velocity	1
VI	REV.Linearizati.			
1	REV Correct Po.1	User set	According to Velocity	1
2	REV Target Val.1	User set	According to Velocity	1
3	REV Correct Po.2	User set	According to Velocity	1
4	REV Target Val.2	User set	According to Velocity	1
5	REV Correct Po.3	User set	According to Velocity	1
6	REV Target Val.3	User set	According to Velocity	1
7	REV Correct Po.4	User set	According to Velocity	1
8	REV Target Val.4	User set	According to Velocity	1
9	REV End Velocity	User set	According to Velocity	1
VII	Temperat. Param			
1	Heat Unit	Select	GJ、MJ、KWH、MWH	1
2	Sensor Position	Select	Inlet/Export	1
2	Temperat. Filter	Select	06~63Sec	1
3	Ent.T Zero CRC	Set Count	00000~ 59999	1

4	Ent.T Range CRC	Set Count	0.0000~1.9999	1
5	Out.T Zero CRC	Set Count	00000~ 59999	1
6	Out.T Range CRC	Set Count	0.0000~1.9999	1
7	Pressure Range	Select	0.6MPa/1.6MPa	1
8	Ent.Temp.Calic	Set Count	0.0000~1.9999	1
9	Out.Temp.Calic	Set Count	0.0000~1.9999	1
VIII	Communication			
1	CommAddres	Select	0~199	1
2	Communica.Rate	Select	1200~14400	1
3	Communica.check	Select	No Parity、Odd Parity、Even Parity	1
4	Communicat.Gap	Select	RESERVE	1
5	Communication	Select	MOD BUS	
6	IrDA Data Type	Select	IrDA Pulse Mode、IrDA Total Mode	1
IX	Factory Adjust			
1	Language	Select	简体中文、ENGLISH	1
2	Meter Correct	Set Count	0.0000~1.9999	1
3	Meter Code 1-4	Factory set	Factory YAER、MONTH (0~59999)	2
4	Multiplier	Set Count	0.0000~3.9999	1
5	Factory Logo	Select	Enable、Disable	1
6	Meter Factor	Set Count	0.0000~3.9999	1
X	Total Parameter			
1	Flow Total Unit	Select	0.001m ³ ~ 1m ³ 、0.001L ~ 1L、 0.001ukg~1ukg、0.001usg~1usg、 0.001kg~1kg、0.001t~1t	1
2	Heat Total Unit	Select	0.001GJ~1.000GJ、 0.001MJ~1.000MJ、 0.001KWH~1.000KWH、 0.001MWH~1.000MWH	
3	Clear Total Key	User set	0~59999	2
4	FWD Total Low	User set	0~99999	1
5	FWD Total High	User set	0~39999	1
6	REV Total Low	User set	0~99999	1
7	REV Total High	User set	0~39999	1
8	Heat Total Low	User set	0~99999	1
9	Heat Total High	User set	0~39999	1
10	Total Display	Select	Flow+、Flow+、Flow-、 Flow+,Flow-,FD、Heat Quantity、 Flow+,Heat、Flow+,Flow-,LM、	1

			F+,F-,FD,LM、 Flow+,Heat,LM、	
XI	Pressure Param.			
1	Pressure Unit	Select	1.000KPa~ 1.000MPa	1
2	P_Sensor Excit	Select	ID=100uA for 20K、 ID=250uA For 8K、 ID=500uA For 4K、 ID=750uA For 2K5	1
3	Pressure Gain	Select	G=02 For 1000mV、 G=04 For 500mV、 G=08 For 250mV、 G=16 For 125mV、 G=32 For 62.5mV、 G=64 For 31.25mV	1
4	Press. Zero CRC	Set Count	0~±9999	1
5	Press. Range CRC	Set Count	0.0000~ 5.9999	1
6	Press. Hi. Alarm	Set Count	0000~ 9999	1
7	Press. Lo. Alarm	Set Count	0000~ 9999	1

There are 2 classes password for the instrument parameter setting. No matter which level of password is used, the user can view the instrument parameters. However, if users want to change instrument parameters, they need to use different levels of passwords.

Level 1 password (00521): the user can change the instrument parameters with password level 1 in the above parameter table;

Level 2 password (fixed value): the user can change all instrument parameters.

Annex 2 Function of Nonlinear Correction

The concept of the nonlinear-correction arithmetic is: in a range of flow rate, the instant value (fixed number) has been corrected into the value we desired.

The function has four fixed points and one end number, so there are five fixed intervals.

The flow-rate fixed points are: one, two, three, four and the end.

The flow-rate fixed intervals are: zero-rate to one, one to two, two to three, three to four, four to the end.

The setting demand of flow rate must follow the principle which is from the little rate to the large rate. For instant, **zero-rate < one < two < three < four < the end.**

A flow-rate fixed point is corresponding with a flow-rate value: one point to one value, two point to two values, and so on.

Notice: All the flow-rate points and values are zero when the converters are product.

Example1: Set all correction parameter

Point No.	The correction points	The target values	The interval used
1	0.100 m/s	0.110 m/s	0.100 m/s
2	0.150 m/s	0.160 m/s	0.100 m/s -- 0.150 m/s
3	0.200 m/s	0.220 m/s	0.150 m/s -- 0.200 m/s

4	0.250 m/s	0.270 m/s	0.200 m/s -- 0.250 m/s
The end	0.300 m/s		0.250 m/s -- 0.300 m/s

Example2: Set part correction parameter (three points)

Point No.	The correction points	The target values	The interval used
1	0.100 m/s	0.120 m/s	0.100 m/s
2	0.200 m/s	0.230 m/s	0.100 m/s -- 0.200 m/s
3	0.300 m/s	0.320 m/s	0.200 m/s -- 0.300 m/s
4	0.321 m/s	0.321 m/s	Unused
The end	0.322 m/s		Unused

Note: Can't use at intervals.

Example3: Set part correction parameter (two points)

Point No.	The correction points	The target values	The interval used
1	0.050 m/s	0.054 m/s	0.050 m/s
2	0.082 m/s	0.080 m/s	0.050 m/s -- 0.082 m/s
3	0.083 m/s	0.083 m/s	Unused
4	0.084 m/s	0.084 m/s	Unused
The end	0.085 m/s		Unused

Note: Can't use at intervals.

After setting: if "OK" is displayed below the correct point or target value, it is proved that the setting is correct. If "??" is displayed below the correct point or target value, it is proved that the setting is wrong. Please reset it.

Flow correction formula

$$Q_{cx} = Q_{c1} + \left(\frac{Q_{C2} - Q_{C1}}{Q_{P2} - Q_{P1}} \right) \times (Q_x - Q_{p1})$$

Q_{cx} ---corrected velocity Q_x ---original velocity

Annex 3 Information Record Function

W803E has data retention memory inside for record-keeping various types of data.

Date Recorded in W803E

Data	Data Format	Record Method	Record Length	Remark
Cumulated Total	10 bit decimal	permanent record	8 byte	
Monthly Total	Data + Total	cycle record	120 groups	record 120 months

Note: the information record function of W803E refers to Meter.

Cycle record:

New records overwrite the oldest records, record keeping N group. For example, 120 groups monthly total means a monthly total record of last month overwrites the record of 120 months ago (10 years of records are keeping).

Record View Method:

- 1, View the record on meter through remote control .
- 2, Through the RS485 function using PC W803E_485 reading month cumulative function view of the software.

Note:

1、 The internal clock doesn't work when the meter dormant , if users need on the total product function, please don't set the instrument after setting up time sleep mode;.

2、 After replacing the meter battery, it will automatically record a monthly total record and the date is January. 1, 2000. The accumulated value is the value of the point of battery replacement. This record is only used as a marker to replace the battery, and does not record the actual monthly gross.

Annex 4 Installing and connecting of pressure sensor

The picture Fig.f4-1 shows how to install the pressure sensor.

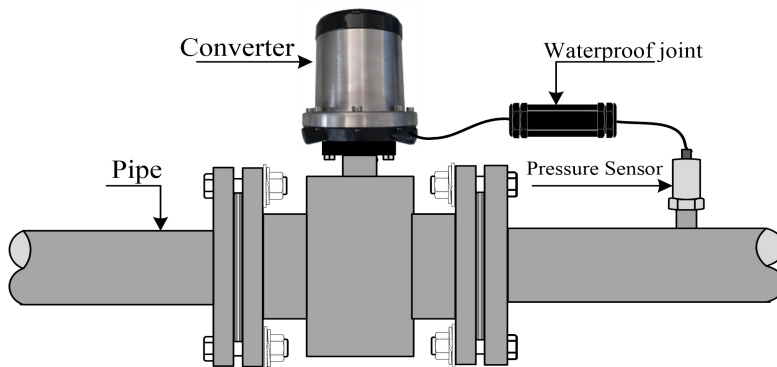

Fig.f 4-1 The installing method of pressure sensor

The wire harness between the converter and pressure sensor has been shown on the picture Fig.f 4-2.

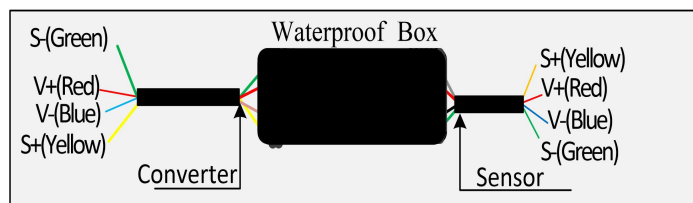

Fig.f 4-2 The wiring order of the water-proof plinth

Annex 5 The selection of P_Sensor Excit and Pressure Gain

If the user does not use the pressure sensor provided by our company, the P_Sensor Excitation and Pressure Gain should be properly selected before calibration.

The converter provide the voltage of $V_{max}=2V$ to pressure sensor. The pressure sensor feedback signal to the converter and the converter measure the pressure.

- P_Sensor Excit is selected according to the maximum equivalent resistance R_s of the pressure sensor at full range pressure, as shown in the following table:

P_Sensor Excit Options	The maximum equivalent resistance of pressure sensor at full range of pressure is R_s
ID=750uA For 2K5	$2.5K\Omega \leq R_s < 3.25K\Omega$
ID=500uA For 4K	$3.25K\Omega < R_s \leq 6K\Omega$
ID=250uA For 8K	$6K\Omega < R_s \leq 14K\Omega$
ID=100uA For 20K	$14K\Omega < R_s \leq 20K\Omega$

- Pressure Gain is selected according to the maximum output signal value of the pressure sensor at full range pressure. Please calculate the gain according to the following formula and select according to the following table:

$$V_{o'} = \frac{ID \times R_s \times V_o}{V_i} \qquad A = \frac{2V \times V_i}{ID \times R_s \times V_o}$$

Formula Description:

$V_{o'}$: the maximum output signal of the pressure transducer which is adapted to the converter at full range of pressure after transformation.

A: Pressure Gain

V_i : Input Voltage of sensor;

ID: the selected P_Sensor Excit;

R_s : the maximum equivalent resistance for pressure sensor full range pressure;

V_o : maximum output signal voltage of pressure sensor at full range of pressure;

Pressure Gain Options	The maximum output signal of the pressure transducer which is adapted to the converter
-----------------------	--

	at full range of pressure after transformation Vo'
G=02 For 1000mV	751 以上
G=04 For 500mV	376-750mV
G=08 For 250mV	187.6-375mV
G=16 For 125mV	93.76-187.5mV
G=32 For 62.5mV	46.88-93.75mV
G=64 For 31.25mV	0-46.87mV

For example: The parameters of the pressure sensors are as follows:

Input Voltage Vi is 3.3V, the range of the Output Voltage Vo is 0-100mV, the pressure measurement scale is 0-1.6MPa.

- Select P_Sensor Excit:

Test the maximum equivalent resistance of the pressure sensor at full range pressure Rs=3.8KΩ

According to the resistance Rs, select the resistance higher than the 'P_Sensor Excit' option, so select the pressure-excited current

ID = 500uA For 4K.

- Select Pressure Gain:

$$V_{O'} = \frac{I_D \times R_s \times V_o}{V_i} = \frac{500\mu A \times 3.8K\Omega \times 100mV}{3.3V} = 57.58mV$$

$$A = \frac{2V \times V_i}{I_D \times R_s \times V_o} = \frac{2V \times 3.3V}{500\mu A \times 3.8K\Omega \times 100mV} = 34.74$$

Formula Description:

Vo': the maximum output signal of the pressure transducer which is adapted to the converter at full range of pressure after transformation.

A: Pressure Gain

Vi: Input Voltage of sensor; ID: the selected P_Sensor Excit;

Rs: the maximum equivalent resistance for pressure sensor full range pressure;

Vo: maximum output signal voltage of pressure sensor at full range of pressure;

So the pressure gain should be G=32 For 62.5mV

Annex 6 Heat Measurement Instructions

1、Temperature calibration method:

The temperature measurement part of the heat meter is connected by the Pt1000 thermal

resistance three wire bridge connection, wiring is as below:

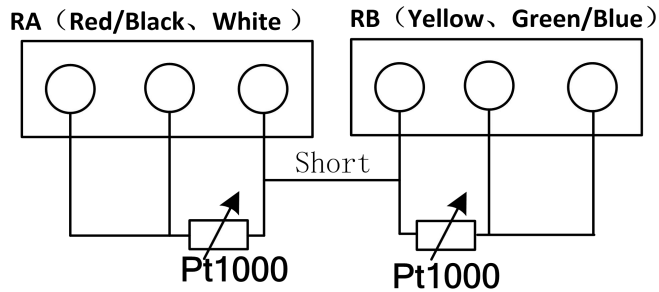

Current zero-point calibration and range calibration should be applied in thermal resistance measurement circuit. The converter has been calibrated in the factory and if calibration is still needed, follow the below steps:

A: use resistance box (connect according to three-wire bridge)

Step 1: Choose 1000Ω resistance and adjust zero-point value (generally 1600) in the entrance (outlet) temperature zero-point parameter until the upper line of the LCD shows “0”.

Step 2: Choose 1535.8Ω resistance and adjust zero-point value (generally 0.6800) in the entrance (outlet) temperature zero-point parameter until the upper line of the LCD shows “1400”.

B、 use blackbody furnace (connect according to three-wire bridge)

Step 1: Put thermal resistance ice water immersion, adjust zero-point value (generally 1010) in the entrance (outlet) temperature zero-point parameter until the upper line of the LCD shows “±0”.

Step 2: Choose temperature 140°C of blackbody furnace, put the thermal resistance into blackbody furnace, adjust zero-point value in the entrance (outlet) temperature zero-point parameter until the upper line of the LCD shows “1400”.

2 Heat calculation method

The heat calculation is done according to CJ128—2007.

Heat calculation:

When the water flows through the installed integrated heat meter or combined meter, the water signal is obtained based on the water flow and temperature from the sensor. The calculation is done based on the water signal and flow time to show the heat released or absorbed.

The format is:

$$Q = \int_{\tau_0}^{\tau_1} q_m \times \Delta h \times d \tau = \int_{\tau_0}^{\tau_1} \rho \times q_v \times \Delta h \times d \tau$$

Q - Heat released or absorbed (J);

qm – Water flow (kg/h);

qv - Water volume flow (m3/h);

ρ – Water density (kg/m³);

Δh - Enthalpy difference between entrance water temperature and outlet water temperature(J/kg);

T – Time (h).

In the format, the destiny and enthalpy is in compliance with the Annex A requirement of CJ128-2007. If the temperature is not integer, the calibration is needed.

Remark: The measurement of the quantity of heat is calculated by using hot melting value of entrance and exit multiplying flow. So the calculated value relates to increment of one second of accumulative flow. That is to say, every time accumulative flow generates one increment, the quantity of heat should be calculated. So unit of accumulative flow should not be adjusted too much, avoiding that it takes long time to generate one accumulative flow increment. Accumulative flow is represented by 10 bits decimal numbers (4294967295). Flow unit is 0.001 m³, 0.01m³, 0.1 m³, 1 m³. The choice of flow unit should meet the demand that it won't overflow in 2-3 years.

Annex 7 Waterproof connector wiring method

In order to strengthen the reliability of waterproof connection, from the middle of March 2020, the original waterproof plug connection structure of W803E converter and its supporting split communication unit will be gradually changed into waterproof junction box and pouring waterproof glue structure. The structure of 4-core waterproof connector used in the extension part of pressure line, heat line or communication line of communication unit is also changed into waterproof junction box and pouring waterproof glue structure.

When the converter and 485 communication unit are ordered, our company has finished the glue filling at the connection between the converter and the communication terminal when leaving the factory. The customer is only responsible for the glue filling treatment of the extension part of the communication line. When ordering split GPRS communication unit or 485 unit separately, the customer shall pour glue at the connection between converter and communication terminal and the extension part of communication line.

The waterproof junction box and waterproof glue will be packaged together with the communication unit in the form of accessories. Please conduct wiring and glue filling according to the wiring instructions

1. Split GPRS structure, customers need to wire and glue according to the position indicated in the figure



2. For ERC, ERK and ERW communication units, the extension of communication line needs to be wired and filled with glue according to the position indicated in the drawing

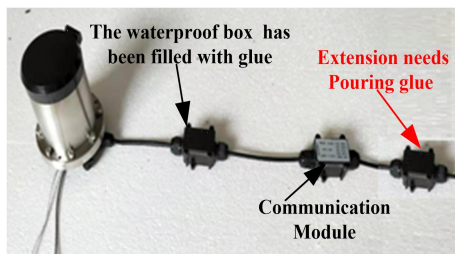

3. The extension of pressure or heat interface needs to be connected and filled by customers according to the position indicated in the drawing



F7.1 wiring and gluing method of W803E converter waterproof box

1. Picture of waterproof box and its accessories

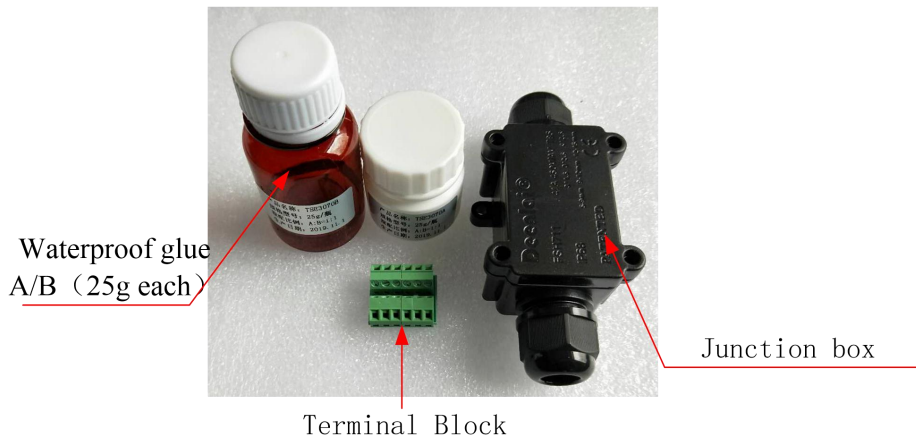

2. Wiring picture of converter and communication terminal waterproof box

The connection line between the split communication unit and the converter end is connected with the red, green, yellow, blue and black lines according to the following figure. If the site is 8-core plug or 8-core wire structure, please first process the wire into 5-core wire (cut off white, brown and orange cores on site) before wiring.

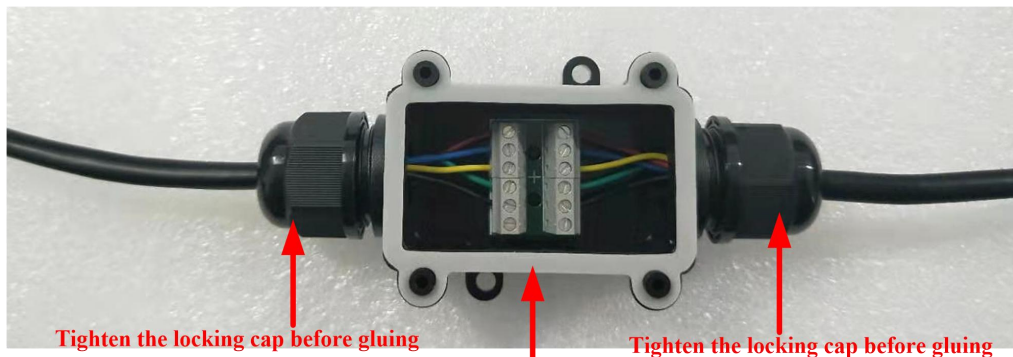

The colors of the wires on both sides of the waterproof block should be connected correspondingly (only the red, green, yellow, blue and black 5-core wires are used)

3. Wiring picture of waterproof box of converter pressure, heat or communication unit extension line

When the output line of converter pressure, heat or communication unit needs to be extended or connected with other equipment, the color of lines on both sides should be connected reliably according to the following figure.

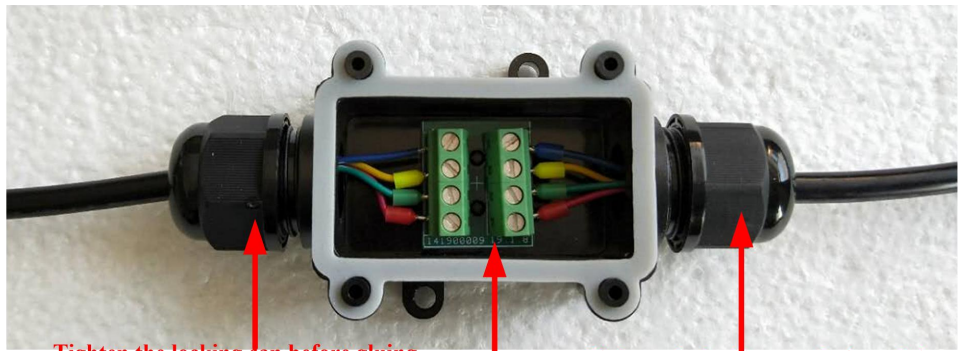

Tighten the locking cap before gluing

Tighten the locking cap before gluing

The colors of the wires on both sides of the waterproof block should be connected correspondingly

4. Filling method of waterproof box

First pour all glue a into plastic bottle B, then mix it fully (you can use disposable chopsticks or other tools to stir) and then pour it into the waterproof box (make sure that the locking caps on both sides have been locked before pouring glue). The glue should pass through the terminals and outlet holes on both sides. Finally, install the upper cover of the waterproof box.



Annex 8 Communication wiring method

1、 Connection diagram of 3.6V battery power supply(ERC)

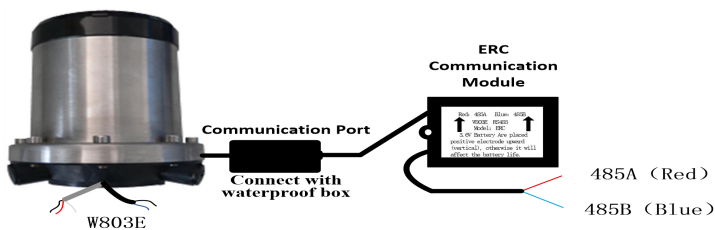

2、 Connection diagram of 8-24V battery power supply(ERW)

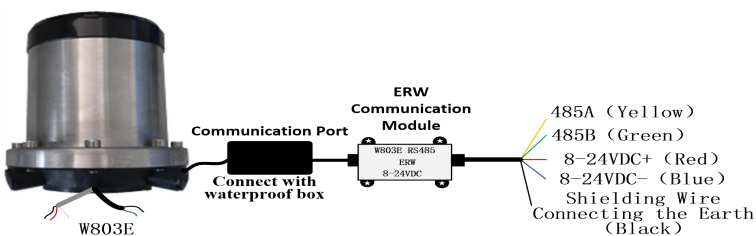

3、 Connection diagram of 3.3-15V battery power supply(ERK)

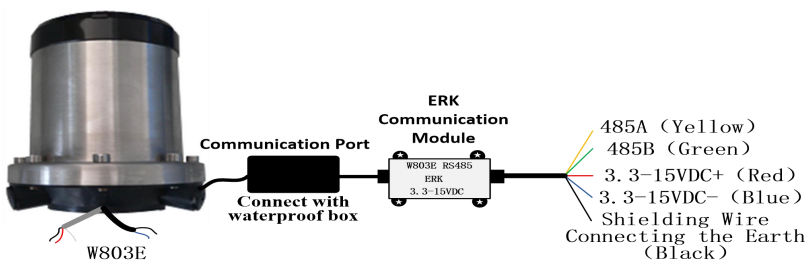

4、 Connection diagram of 12-24V battery power supply(ERWI)

Note: please ensure the power supply of 12-24vdc , otherwise 485 and I + / - functions can not work.

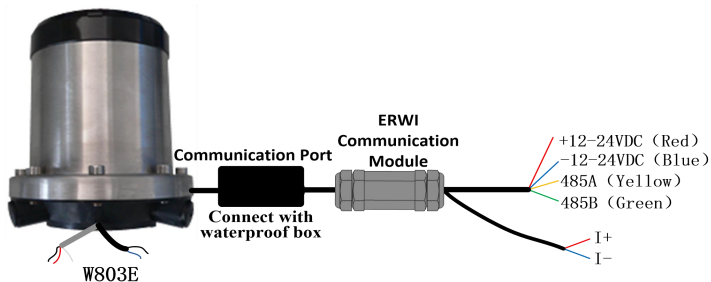

5、 Connection diagram of 3.3-15V battery power supply(ETK)

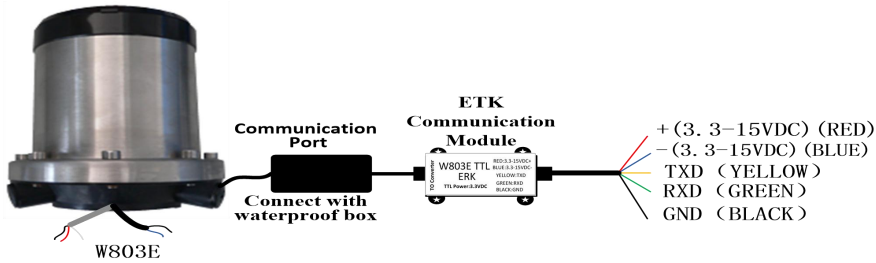

6、 Connection diagram of HART communication:

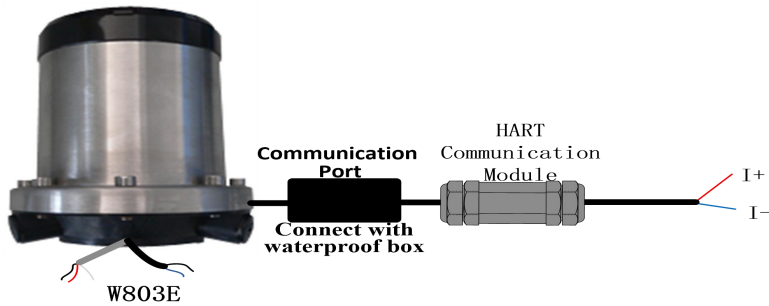

7、 Connection diagram of 3.6V battery power supply(ERCT):

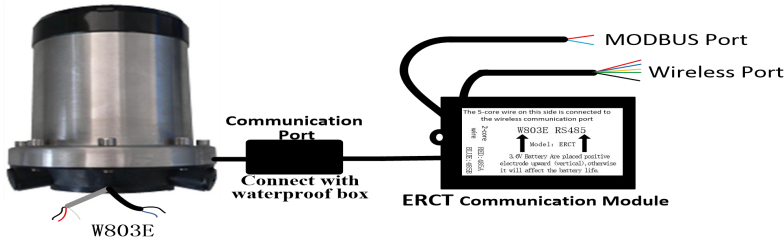

8、 Connection diagram of 8-24V battery power supply(ERWT):

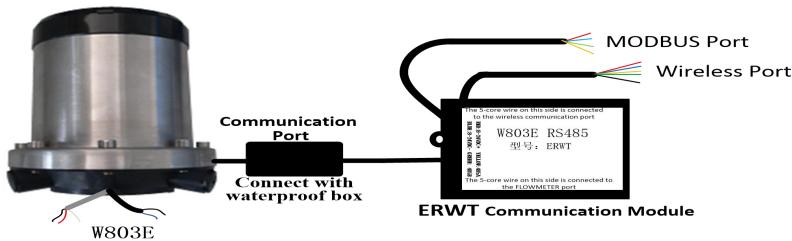

Annex 9 Instructions for HART communication module

1. Summarize

W803E battery-powered electromagnetic flowmeters (“W803E flowmeters” for short) have the communication connectors. When the connectors joint with the current output module, the flowmeters will output the current by two wires. At the same time, it will

communicate with the operators.

2.Connection

1).The steps

a).Find the interface of current output module(mark in the figF9.1) and joint with the communication connector of W803E flowmeter.

b).Prepare a power source which supplies the voltage DC24V.The positive electrode of voltage connects with the red wire of current output module.Meanwhile the negative electrode of voltage connects with the end a load resistance in series and the other end of resistance connects with the blue wire.

c).The hand operator owns two connectors.Connect them with the red and blue wires of the module.

The figF9.2 marks this connection in detail.

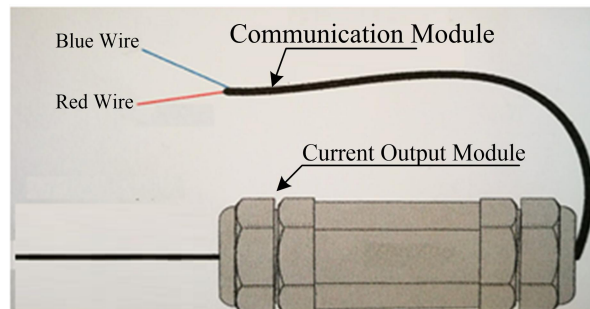

FigF9.1 The sketch of current output module

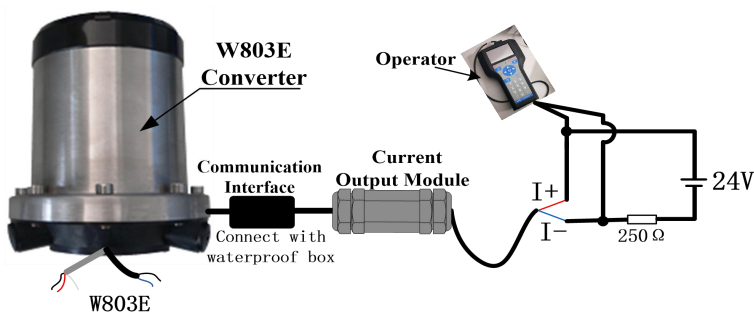

FigF9.2 The sketch of connection

2).The explain

There are several points need to explain in detail.

a).The current module outputs the current between 4 and 20 mA.

b).The resistance value is 250 ohm.

c).The output current value change with the measure interval of W803E flowmeter.At the same time,the data of the operator change with the interval likewise.(e.g. If the interval of W803E flowmeter is 15 seconds,the data will be refreshed every 15 seconds.)

3.Communication Operation

There are three points of the operation need to explain in detail.

a).The Operator of Emerson(type:475) is applied.

b).If the operator does not use DD, three data can be read on the screen by default: instantaneous flow value, flow percentage and current output value.

c). If the operator use DD, eight data can be read on the screen by default: instantaneous flow value, total cumulative value, forward cumulative value, reverse cumulative value, flow velocity , flow percentage, output current value and fluid conductivity ratio.

d). If the operator does not use DD, three data can be modified: flow unit, damping time and flow range .

e). If the operator use DD, more data can be modified: sensor diameter, flow direction, flow range, flow unit, damping time, small signal removal, pulse equivalent, upper alarm value, lower alarm value, sensor coefficient value ,etc..

NOTICE:

1).After the parameters are modified by operator, the parameters of W803E flowmeter need to wait for a moment to change.

2).When W803E flowmeter is communicating,it works in the measure state.(There is a battery symbol display on the screen of W803E flowmeter)

4.The Manual of Operator

If the user orders operator product by our company, please consult the manual of operator.And if the user orders others' operator, please consult the manual of others correspondingly.

Annex 10 Precautions for use of converter

1、 Installation environment requirements:

The converter shall not be installed at a place with high ambient temperature and direct sunlight. If it must be used in this environment, it is recommended to use an instrument box or other equipment for shielding, otherwise the service life of the LCD module may be shortened or damaged.

2、 Pressure requirements in the shell cavity

If the customer opens the housing by himself and re pressurizes and seals, please note that the pressure in the housing cavity shall not exceed 0.1Mpa. The components in the meter may be damaged to varying degrees after overpressure.

3、 Picture of LCD module damage on site



FigF10.1 After a long time of direct sunlight, the LCD module cannot display normally